

REVISITING LARGE SIZE DIRECT SHEAR TESTING OF ROCK MASS FOUNDATIONS

G. Barla*, F. Robotti[†] and L. Vai[‡]

* Politecnico di Torino, Department of Structural and Geotechnical Engineering
10129 Torino, Italy
e-mail: giovanni.barla@polito.it

Keywords: Dams, Direct shear test, Peak strength, Residual strength, Rock joints, Concrete-rock interfaces

Abstract: *A newly developed apparatus for large size in situ shear testing of concrete-rock interfaces is described in this paper. Attention is placed on the development of the main components forming the apparatus and the advanced monitoring features which allow for continuous measurements of both the normal and shear displacements and loads by means of advanced data acquisition systems. A typical test performed on the granite rock mass foundation of the Cumbidanovu Dam (Italy) will be described together with the results obtained.*

1 INTRODUCTION

The design of geotechnical structures in rock masses such as dam foundations and rock slopes requires one to assess the shear strength of rock joints and discontinuities. Also of interest is the performance of such a test on concrete-rock interfaces. This is usually done by direct shear testing in the laboratory and, preferably, in situ. The latter type of test is however rather complex, time consuming, and expensive, with the consequence that it is performed in very limited number so as to make it difficult if not impossible to assess the shear strength properties with any statistical significance.

This paper is intended to describe a newly developed apparatus for large size in situ shear testing of concrete-rock interfaces and rock joints, with size of 1.60 x 1.00 m. The most attention has been placed on the development of the mechanical components forming the apparatus and the advanced monitoring features which allow for continuous measurement of both the normal and shear displacements and loads with high accuracy by means of an advanced data acquisition system.

A test can be performed in closely controlled conditions and while obtaining directly the results of testing in graphic and numerical form. In particular, a step-wise procedure can be adopted on a single interface so that both the peak and residual shear envelopes can be obtained. The results of a direct shear test on the rock mass foundation of a 72.7 m high concrete gravity dam, presently under construction in Orgosolo (Italy), will be reported in detail.

[†] Agisco, Milano, Italy

[‡] Geodes, Torino, Italy

2 DAM SITE

The motivations for developing the new in situ direct shear testing apparatus described in this paper are due to the undergoing construction, at the Cumbidanovu Dam site (near Nuoro, Sardinia, Italy, Figure 1a), of a 72.7 m high (maximum) concrete gravity dam and the requirement by the Italian Dam Authorities to perform direct shear tests on the concrete-rock interface and rock discontinuities, when the excavation works of the dam foundations were completed. The dam, with a total concrete volume of $3 \cdot 10^5 \text{ m}^3$, has a slightly curved planimetric axis and a total crest length of 227.6 m. With a reservoir volume of $13 \cdot 10^6 \text{ m}^3$, the dam is expected to supply water for irrigation purposes of approximately 2800 ha of cultivated land. A view of the right-side abutment of the dam, with the excavation works nearly completed and the provisions needed for starting concrete casting being developed, is shown in Figure 1b.

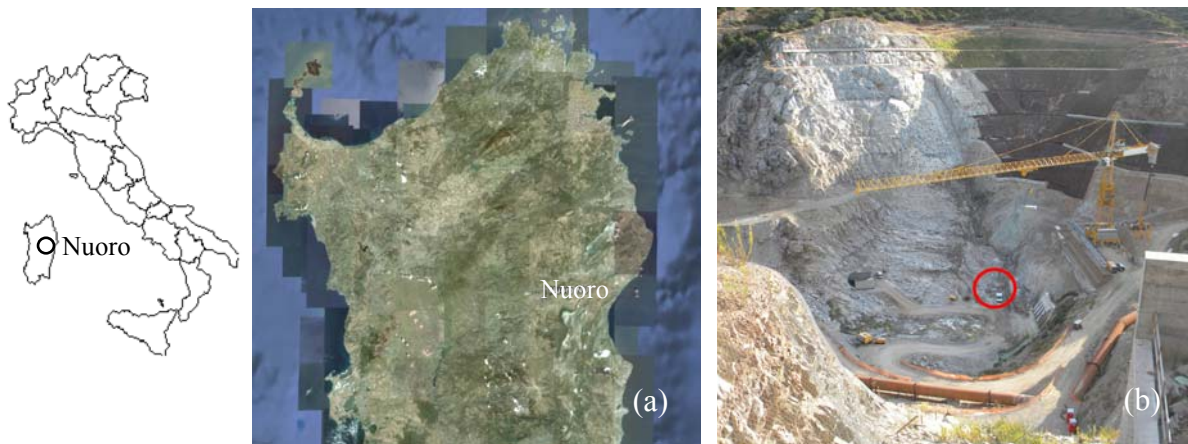

Figure 1: (a) Location of the dam site. (b) View of the foundation surface (right abutment, test site in red circle)

The dam foundation is characterized by the presence of a granite rock mass, rather complex geologic features (shear/fault zones), multiple rock joint sets, and significant differences in rock mass quality on the two slopes. A batholith composed of grey massive granite (GSI in the range 53-82, mean value 69) is present on the right slope, with arenitic granite upstream of the right abutment. The left slope is composed of light-grey microgranite (GSI in the range 63-82, mean value 67) and light-red granite, which extends on the plane foundation surface on the downstream side (GSI in the range 50-77, mean value 63).

On the upstream side of the dam a sheared/faulted red granite is present which extends from the left abutment toe to the right abutment toe approximately and covers nearly a quarter of the dam foundation surface. Here the rock mass is of fair to poor quality with GSI ranging from 37 to 57, with mean value 48. The direct shear tests carried out with the equipment described below have been performed for the purpose of characterizing the concrete-rock interface in both the light red granite and the sheared/faulted red granite. It is noted that the results of the testing work described below pertain to the latter zone (Figure 1B).

3 NEW DIRECT SHEAR TEST APPARATUS

Large size in situ direct shear tests are generally conducted in adits, where the reaction for the normal load is obtained from the opposite wall of the adit, or on rock surface using anchors fixed into the rock adjacent to the site. Wherever possible, the direction of the shear force is chosen so that it is the same as the likely direction of sliding. The test procedure which is substantially similar to that of the laboratory direct shear test is described in the ISRM Suggested Methods for Rock Characterization, Testing and Monitoring (2007)¹. One problem with this type of test is the complexity of its performance, the high costs involved, etc., with the consequence that it is not conducted very often and in all cases the number of tests carried out is limited so that the results obtained are thought to be of low statistical significance.

With this in mind and the need to perform in situ direct shear tests on the dam foundation described above, the authors decided to develop a novel direct shear testing apparatus. This was designed and constructed by Agisco (Milano, Italy) in line with a testing equipment originally developed by Consonda in the seventies², however with the intent to improve it based on previous experience and most of all by using all the advanced computer based control and data acquisition systems presently available. A rendering of such a test equipment in the typical arrangement for testing a concrete-rock interface (size 160x100 cm) is shown in Figure 2: The design drawings (typically the reaction systems for normal and shear loads application) are given in Figure 3. Some of the relevant features of the newly developed apparatus are briefly described below.

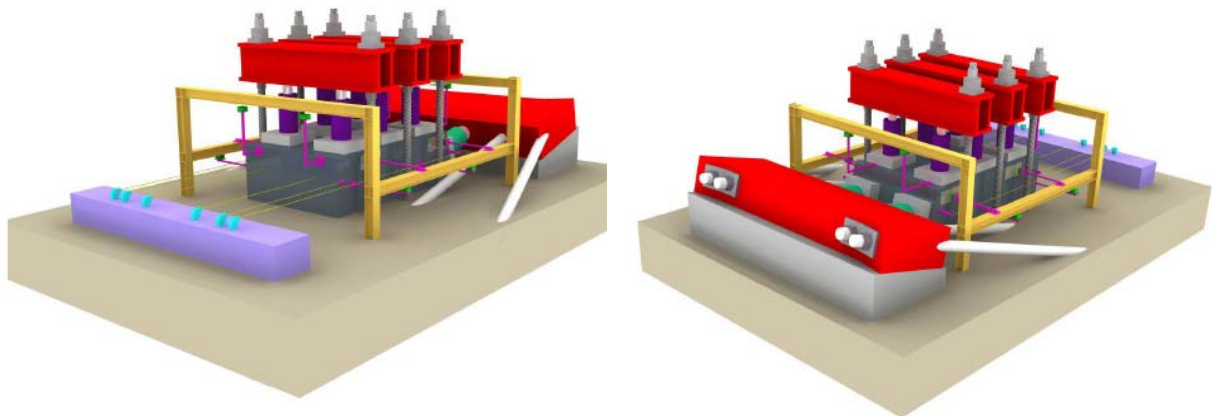

Figure 2: Rendering of the new direct shear apparatus

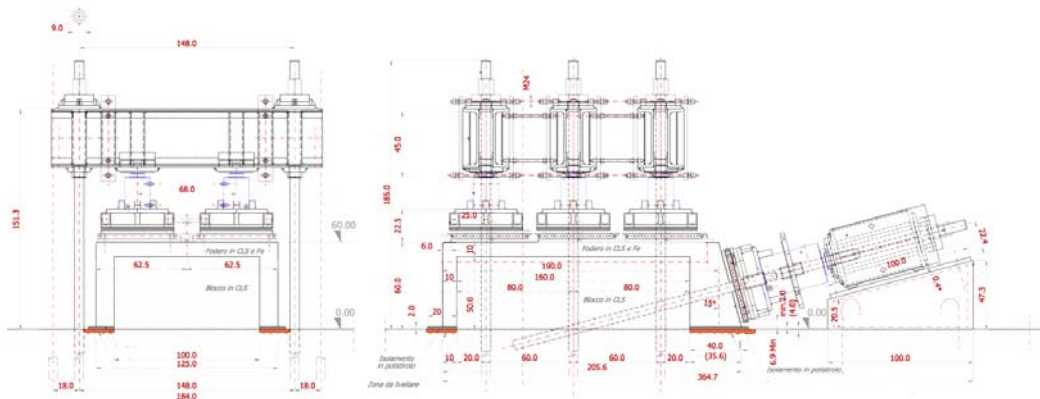

Figure 3: Detailed drawing of the new direct shear apparatus

3.1 Loading systems

The apparatus has been designed and constructed so as to achieve the desired performance without impairing its use in sites which in general are not easy to reach. The main components of the loading system are the reaction elements for applying the normal load and shear force, the hydraulic jacks capable to maintaining/applying them, the low-friction rollers, the steel plates to apply the desired loads, etc. As shown in Figures 2 and 3, the apparatus comprises the following:

- 3 reaction beams anchored to the rock mass by 6 Dywidag rock anchors (DYWIDAG 63T0000, 63 mm diameter) for applying the normal load. The beams are 1840x450x250 mm in size and ensure that no significant displacements occur with the maximum allowed normal load of 6000 kN being applied (Figure 4);
- 6 hydraulic vertical jacks (1000 kN maximum load each, 130 mm diameter), 3 rows with 2 jacks each, connected to the same hydraulic circuit so that each jack is applying the same load. With the hydraulic pressure being known, one is able to know the normal load applied to the test block;
- 1 reaction beam anchored to the rock mass by using 4 Dywidag rock anchors inclined 15° with respect to the horizontal for applying the shear force. The beam is 1000x450x2000 mm in size and such as to make the displacements under the maximum applied force negligible;
- 2 hydraulic horizontal jacks (2400 kN each, 210 mm diameter), acting similarly as the vertical jacks and applying the shear force;
- C130 rollers introduced under the loading plates as low-friction devices to ensure that at any given normal load the resistance to shear displacement is negligible;
- load distribution plates in laminated elastomer, with 15 N/mm² maximum working pressure.

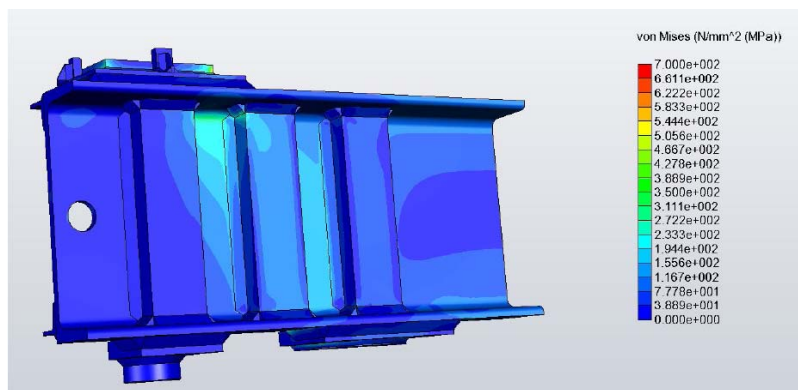

Figure 4: Stress distribution in the reaction beam under the maximum normal load applied. The computed maximum displacement in the beam is 0.33 cm (Finite Element Modelling Simulation)

3.2 Measuring and data acquisition systems

The measuring system comprises 20 displacement transducers (14 LVDT and 6 potentiometer type), 4 thermal transducers, 2 pressure gages. The maximum displacements that can be measured are 55 mm (0.02 mm accuracy) and 220 mm (0.02 mm accuracy), respectively for the LVDTs and the potentiometer transducers. The pressure gages can measure a maximum 10 MPa pressure with 0.5% accuracy. Figure 5 shows the arrangement of the displacement transducers: UDI for normal displacement, LRI for lateral displacement, and FWI for shear displacement.

The layout of the data acquisition system is shown in Figure 6. It is noted that the system

is such as to have two independent chains of transducers and two rugged personal computers for independent data processing, visualization and storage. This is an important feature of the system which allows for continuous and redundant monitoring of the data which are being obtained during testing. The use of a 16 bit converter allows the displacement and pressure measurements to be performed with a frequency of 1 reading per second.

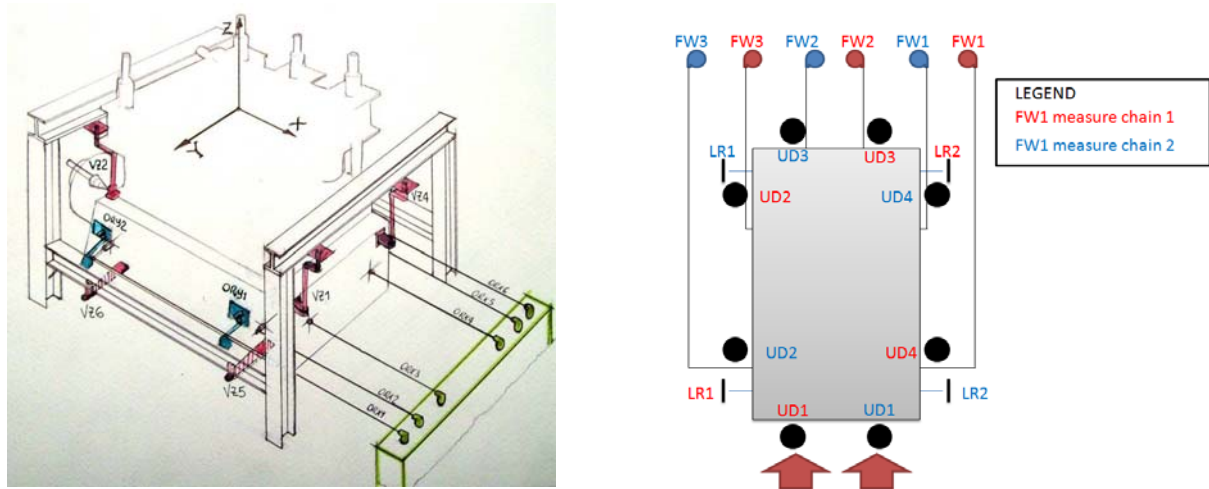

Figure 5: Arrangement of displacement transducers

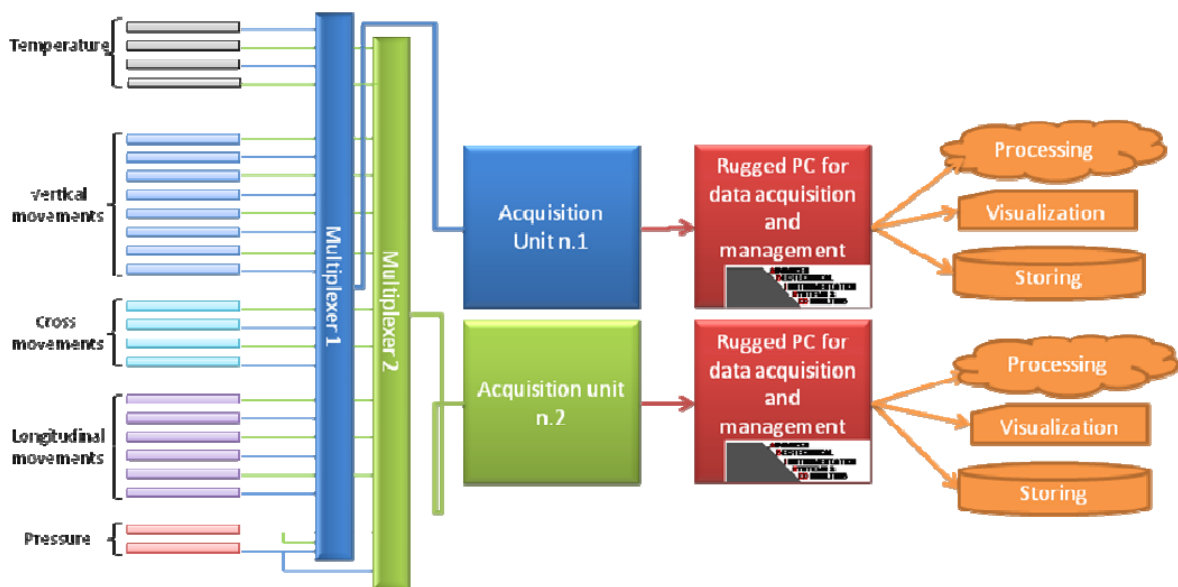

Figure 6: Layout of the data acquisition system

3.3 Proposed test procedure

The usual test procedure adopted for performing direct shear tests calls for a constant normal stress to be applied with the shear force being gradually increased until sliding takes place. As illustrated in Figure 7a and based on the ISRM suggested methods¹, the peak shear strength $\tau_p)_1$ of the test surface is reached under the chosen normal stress level $(\sigma_n)_1$ by applying the shear force “either in increments or continuously in such a way as to control the rate of shear displacement”. After reaching the peak strength $\tau_p)_1$ the shear stress-shear displacement curve is plotted as shearing is continued under the same

constant normal stress up to obtaining the corresponding residual shear strength $\tau_r)_1$. As stated in the ISRM suggested methods¹, “having established a residual strength, the normal stress may be increased or reduced and shearing continued to obtain additional residual strength values”.

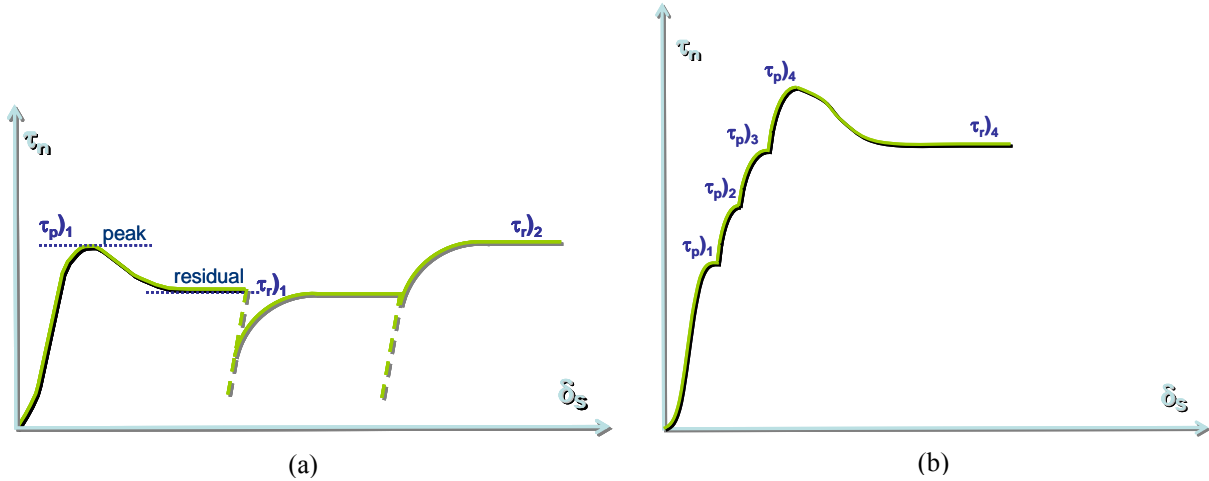

Figure 7: Schematic visualization of direct shear test
(a) procedure according to ISRM¹, (b) proposed step-wise procedure

Considering the newly developed shear test apparatus and its advanced control, monitoring, and data acquisition features, an alternate test procedure is proposed for direct shear testing in order to obtain the peak strength envelope from a single test using the step-wise procedure illustrated in Figure 7b. This is somewhat similar to the “multiple failure state test” described in the ISRM suggested methods for triaxial laboratory testing³.

As shown in Figure 7, with the standard procedure the peak shear strength $\tau_p)_1$ of the test surface is reached under the chosen normal stress level $(\sigma_n)_1$ by applying the shear force continuously. Given that one is in position with the newly developed test apparatus to observe in real time the shear stress-shear displacement curve, this peak strength value can be readily obtained. The normal stress is then increased in one step from $(\sigma_n)_1$ to $(\sigma_n)_2$ and the shear force is increased keeping the normal stress constant until the corresponding peak shear strength $\tau_p)_2$ is observed.

This stepwise procedure is continued until a chosen $\tau_p)_4$ value is reached under the normal stress $(\sigma_n)_4$. With this normal stress kept constant, the shear stress-shear displacement curve is plotted as shearing is continued under the same constant normal stress up to obtaining the corresponding residual shear strength $\tau_r)_4$. It follows that, as with the standard procedure, the normal stress may be reduced and shearing continued to obtain additional residual strength values.

5 TEST EXAMPLE

One of the direct shear tests recently carried out at the Cumbidanovu Dam site by using the newly developed shear test apparatus and the above proposed test procedure will be described in the following. This direct shear test was performed on the upstream side of the dam foundation on the sheared/faulted red granite of fair to poor quality (Figure 1b). The purpose was to assess the shear strength characteristics of the concrete-rock interface.

Figure 8 shows in (a) the rock surface prepared for testing and in (b) the direct shear test apparatus. It is noted that the concrete block which is 60 cm high was casted directly on the rock surface. In order to avoid possible failures of the block due to stress concentrations during shearing steel reinforced concrete was used, leaving however a 10 cm thick un-reinforced layer adjacent to the rock surface.

The surface topography was mapped by point measurements with 5 cm spacing (i.e. the horizontal distance between two subsequent measurement points along two orthogonal lines) in order to estimate the rock surface roughness before and after shearing. Figure 9 gives a 3D visualization of the testing surface in the two conditions.

It is noted that this surface is extremely rough both before and after shearing. If one uses the available methods for assessing the roughness characteristics^{4,5}, one would estimate a value of the Joint Roughness Coefficient (JRC) of the surface before shearing higher than admissible (20) and after shearing as high as 15 - 20 .

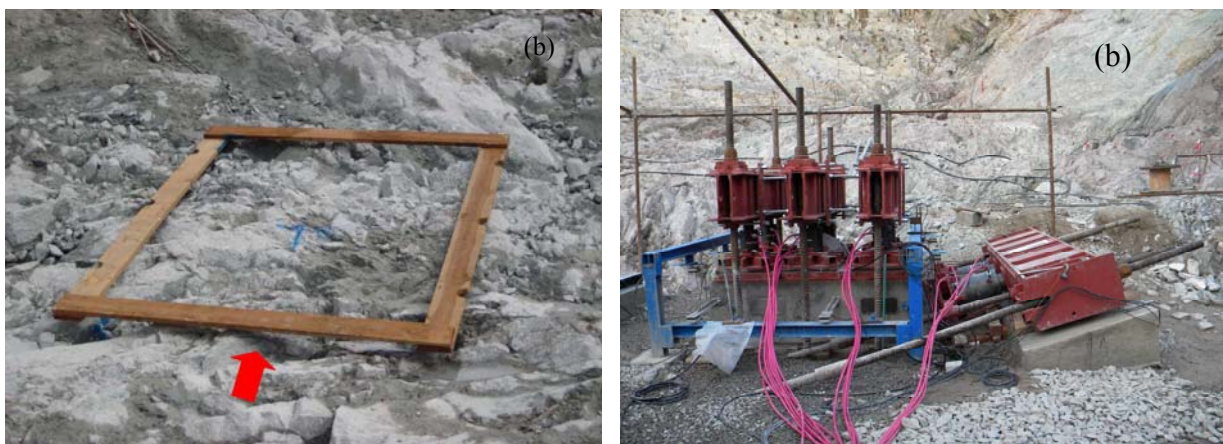

Figure 8: Testing site: (a) rock surface to be sheared, (b) photograph of the shear test apparatus

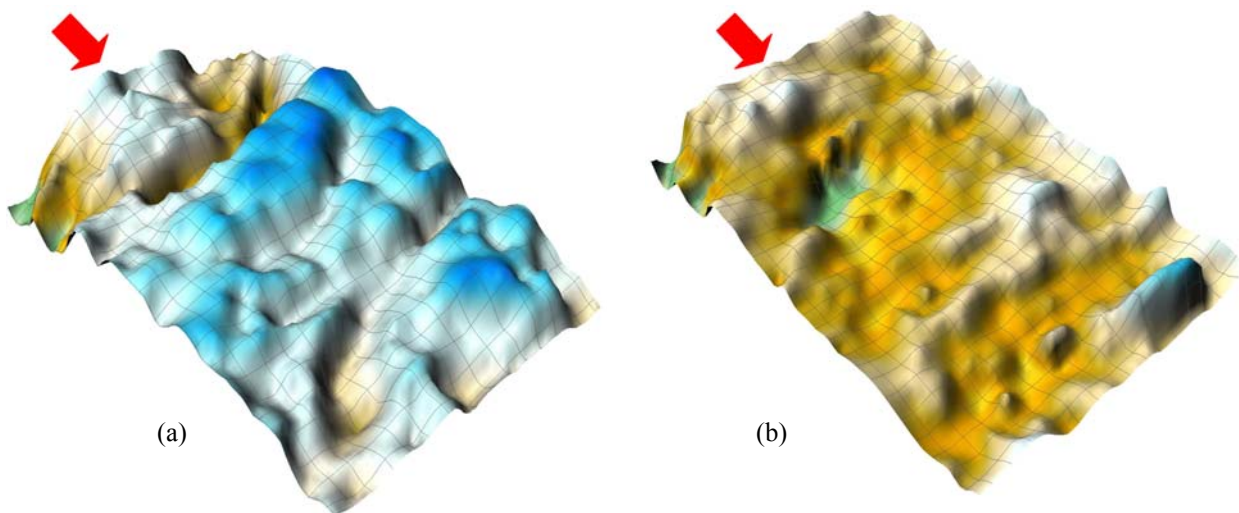

Figure 9: 3D visualization of the rock surface to be sheared: (a) before shearing, (b) after shearing

The rock mass in the testing area is blocky, from interlocked to poorly interlocked, characterized by the presence of three to four joint sets, spaced at 10 - 20 cm, with a separation of < 1 mm, smooth to slightly rough, and weathered with, in cases, soft infilling, with GSI ranging from 37 to 57 and mean value 48.

The stepwise testing procedure adopted can be summarized as follows for the determination of the peak $\tau_{p,i}$ and residual $\tau_{r,i}$ shear strengths of the test surface:

- 1st loading step, normal load $(N)_1$ 850 kN \rightarrow normal stress $(\sigma_n)_1$ 0.53 MPa;
- 2nd loading step, normal load $(N)_2$ 1650 kN \rightarrow normal stress $(\sigma_n)_2$ 1.03 MPa;
- 3rd loading step, normal load $(N)_3$ 2350 kN \rightarrow normal stress $(\sigma_n)_3$ 1.47 MPa;
- 4th loading step, normal load $(N)_4$ 3260 kN \rightarrow normal stress $(\sigma_n)_4$ 2.03 MPa.

Figure 10 gives in (a) the history of both the normal load N and shear force S versus time t during testing and in (b) the shear force S - shear displacement δ_s diagram. It is shown that the testing performance is well in line with the step-wise procedure adopted. It is of interest to underline that during testing also the dilatancy angle α can be measured continuously based on the the normal displacement δ_n - shear displacement δ_s diagram, thus observing its progressive decrease, as the steeply inclined peaks of the discontinuity surface are cut off or severely damaged.

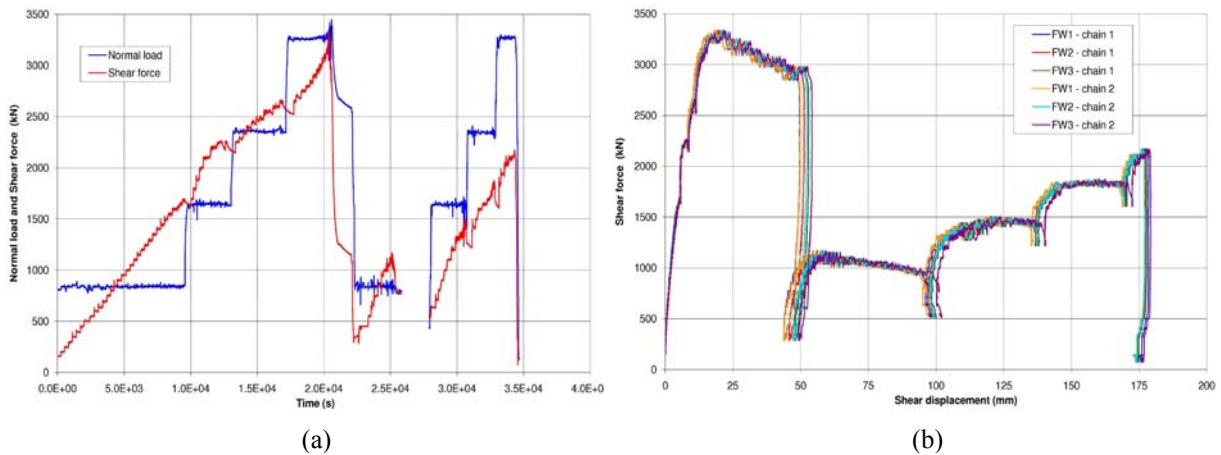

Figure 10: Results of direct shear test on concrete-rock interface with stepwise procedure
 (a) Normal load N and Shear force S versus time, (b) Shear force S versus Shear displacement δ_s

Diagrams of peak τ_p and residual τ_r shear strength versus normal stress σ_n can be plotted as shown in Figure 11a and b based on all the data made available from one single test. It is noted that with the testing procedure adopted, the data are being obtained continuously and with a high sampling rate. Thus, the diagrams are characterised by a significant number of data points which help in the definition of the shear strength envelope. Also plotted in Figure 11a and 11b is the variation of the dilation angle as the normal stress is increased.

One may now use the Mohr-Coulomb criterion to express the peak and residual shear strength versus the normal stress as shown in Figure 11c according to:

$$\tau = c' + \sigma_n \tan \phi'$$

to obtain (c' = cohesion, ϕ' = friction angle):

Strength	ϕ' (°)	c' (kPa)
peak value	32.3	734.4
residual value	24.4	425.8

Table 1: Mohr-Coulomb strength parameters of concrete-rock interface.

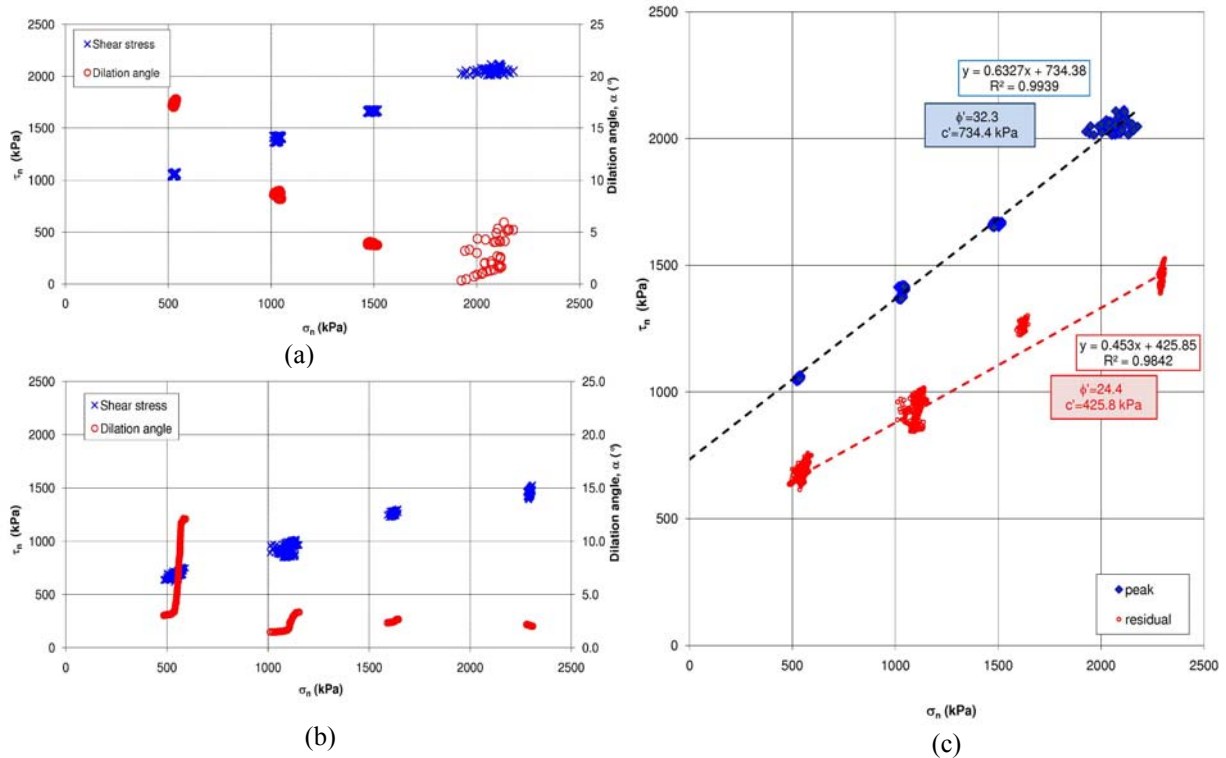

Figure 11: Results of direct shear test on concrete-rock interface with step-wise procedure
 (a), (b) Plots of shear strength and dilation angle versus normal stress: (a) peak and (b) residual values
 (c) Plot of shear strength versus normal stress, peak and residual Mohr-Coulomb envelopes.

6 CONCLUSIONS

A newly developed apparatus for large size in situ shear testing of concrete-rock interfaces and rock joints, with size 1.60 x 1.00 m has been described. Attention has been paid to the mechanical components forming the apparatus and its advanced control/monitoring features, which allow for continuous measurement with high accuracy of both the normal and shear displacements/forces and for performing the test in closely controlled conditions by means of advanced control/acquisition systems.

A significant step forward in direct shear testing has been made with the new apparatus based on the adoption of a step-wise procedure, which allows one to obtain both the peak and residual strength envelopes for the interface from a single test. This is somewhat similar to the “multiple failure state test” described in the ISRM suggested methods for triaxial laboratory testing.

The new shear test apparatus has been used successfully for concrete-rock interface characterization at the Cumbidanovu Dam site (Nuoro, Sardinia, Italy), where a 72.7 m high (maximum) concrete gravity dam is being constructed. A test example has been described with reference to a sheared/faulted red granite.

Acknowledgements: We would like to acknowledge the permission to prepare this paper given by Consorzio di Bonifica della Sardegna Centrale, Nuoro (Italy), Owner, and Itinera S.p.A., Alessandria (Italy), Contractor, Cumbidanovu Dam Project. Also to be acknowledged is the help of many people who contributed to the design and development of the shear test apparatus, to the testing work performed and the subsequent analysis of data.

REFERENCES

- [1] R. Ulusay R. & J.A. Hudson, *The complete ISRM Suggested Methods for Rock Characterization, Testing and Monitoring: 1974-2006. Determining shear strength. 1. In situ determination of direct shear strength.* 165-170. (2007).
- [2] G. Barla, *Rock mass characterization for design and construction of underground cavities and tunnels". Geotechnical Engineering in Italy. An overview, 1985. Published by AGI, Associazione Geotecnica Italiana.* 271-315. (1985).
- [3] R. Ulusay R. & J.A. Hudson, *The complete ISRM Suggested Methods for Rock Characterization, Testing and Monitoring: 1974-2006. Suggested methods for determining the strength of rock materials in triaxial compression: Revised version.* 159-164. (2007).
- [4] R. Tse & D.M. Cruden, *Estimating Joint Roughness Coefficients. Int. J. Rock Mech. Min. Sci. & Geomech. Abstr.* 16, 303-307. (1979).
- [5] B.S.A. Tatone & G. Grasselli, *A new 2D discontinuity roughness parameter and its correlation with JRC. Int. J. Rock Mech. Min. Sci.* (2010).